

Connection to
SSD1309 OLED

BS1, BS = H
-> 8080 par. bus

Connection to U1273A
main PCB

Programming connector
(Lattice 2x5 pin standard
on 1.27mm pitch header)

Debug Header

$$R = (V_{cc}-3V)/10\mu A$$

U1273A OLED Interface

Size	Section	Revision
A4	Interface and FPGA	R 0
Date:	2021-01-08	www.kitsune-denshi.net
File:	display-if.dch	Sheet 1 / 2

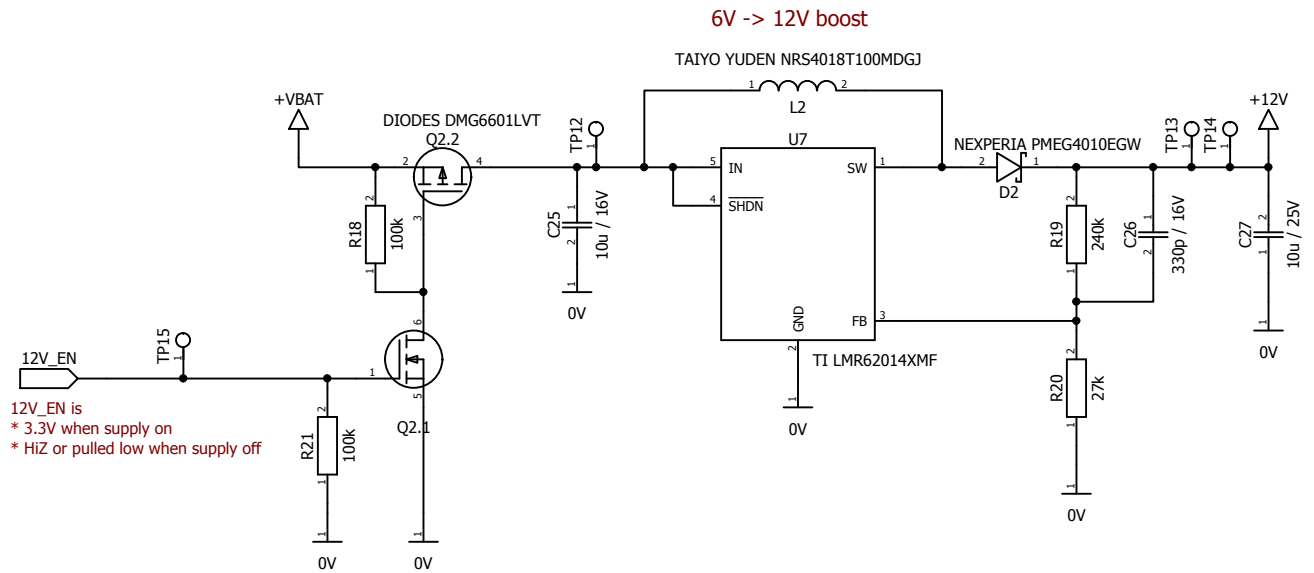
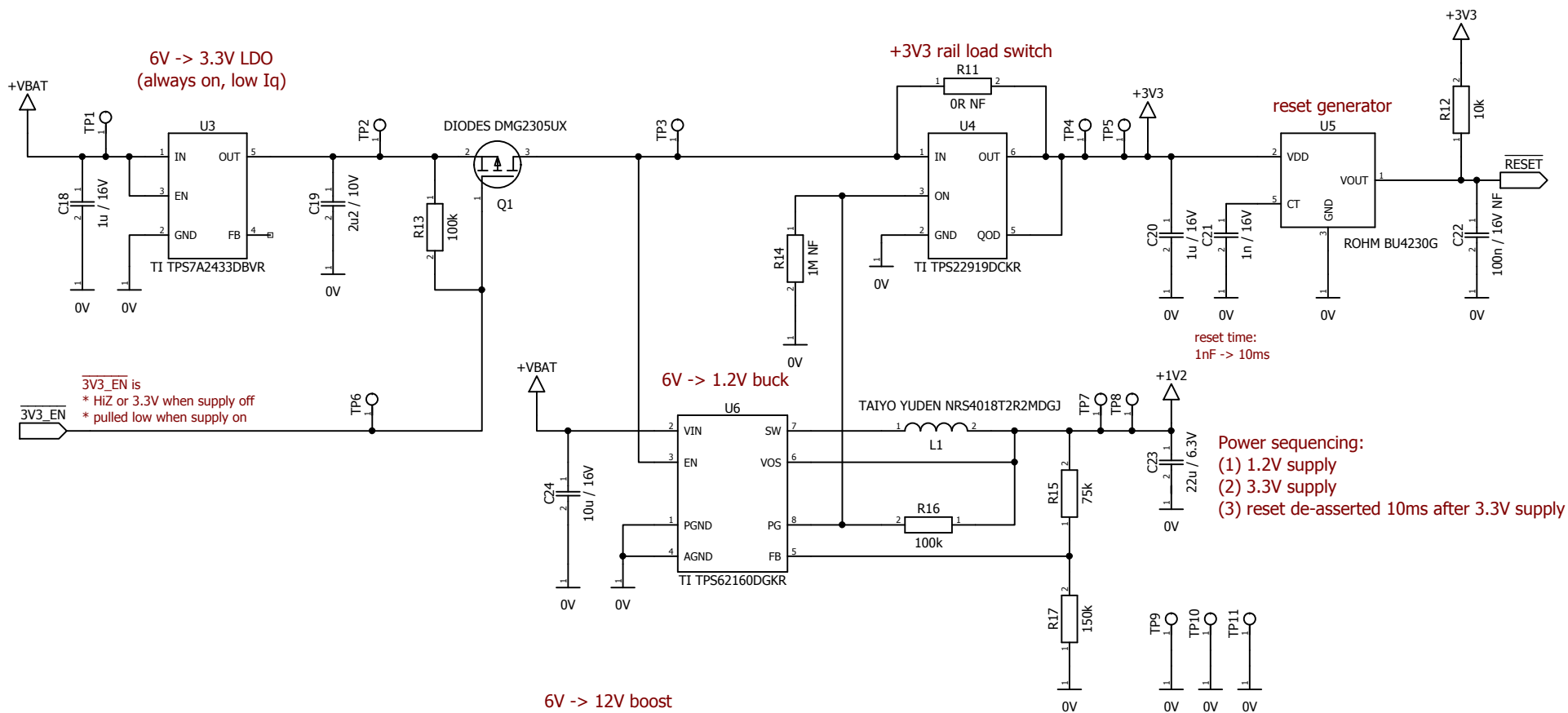

U1273A OLED Interface		
Size	Section	Revision
A4	Power Supplies and Reset	R 0
Date:	2021-01-08	www.kitsune-denshi.net
File:	display-if.dch	Sheet 2 / 2
CC BY-SA https://creativecommons.org/licenses/by-sa/4.0/		